

USER MANUAL

P I E G A S U B M E D I U M

E X P E C T M O R E

CONTENT

1	CONTENT	2
2	IMPORTANT SAFETY INSTRUCTIONS.....	3
3	OPERATING ELEMENTS SUB MEDIUM.....	4
4	WIRELESS SURROUND SOUND WITH WISA	5
4.1	WIRELESS CONNECTION TO WISA-ENABLED	5
	DEVICE	5
4.2	CONNECT YOUR SUBWOOFER TO A	
	PIEGA ACE WIRELESS SPEAKER	5
4.2.1	SUB MODE ACE WIRELESS SPEAKER.....	6
5	CONFIGURATION	7
5.1	POSITIONING	7
5.2	WIRELESS ON/OFF	7
5.3	PHASE.....	7
5.4	OUTPUT	8
5.5	VOLUME.....	8
5.6	FREQUENCY	8
6	ANALOG IN- AND OUTPUTS	9
6.1	RCA INPUT/OUTPUT	9
6.2	SETUP INTERFACE FOR AUDIOPHILES	9
7	RESET	9
8	FIRMWARE UPDATE	9
9	STATUS INDICATOR.....	11
10	TECHNICAL DATA.....	11
11	DECLARATION OF CONFORMITY	12

2 IMPORTANT SAFETY INSTRUCTIONS

Read all safety instructions carefully.

1. Heed all warnings.
2. Follow all instructions and recommendations.
3. Do not use this apparatus near water.
4. Clean with dry and soft cloth only.
5. Do not install near any heat sources such as radiators, heat registers, stoves, or other devices that produce heat.
6. Protect the power cord from being stepped on or pinched, particularly at plugs, convenience receptacles, and at the point they exit from the apparatus.
7. Only use accessories or attachments approved by the manufacturer.
8. Do not defeat the safety purpose of the polarized type plug. If the provided plug does not fit into your outlet, consult an electrician for replacement of the obsolete outlet.
9. Unplug this apparatus during lightning storms or when unused for long periods of time.
10. Refer all servicing to qualified personnel. Servicing is required if the apparatus has been damaged in any way, e.g., the power supply cord or plug is damaged, liquid has been spilled, or objects have fallen into the apparatus. Equally, if exposed to rain or moisture, it does not operate normally or has been dropped.
11. The power plug should be easily accessible to disconnect the equipment.
12. Warning: To reduce the risk of fire and electric shock, do not expose this apparatus to rain or moisture.
13. Do not expose the apparatus to dripping or splashing, and do not place objects filled with liquids, such as vases, on the apparatus.
14. Maintain 150 mm safety clearance all around the apparatus to ensure adequate ventilation.
15. The ventilation should not be impeded by covering the ventilation openings with items. Strictly follow the manufacturer's installation instructions.
16. Do not place objects with naked flames, such as lit candles, on the apparatus.
17. This apparatus is approved for indoor use only.

3 OPERATING ELEMENTS SUB MEDIUM

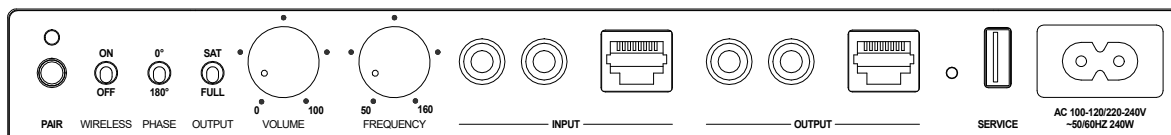

PAIR	Starts the connection to your Tx loudspeaker or WiSA-enabled device (TV/transmitter).
STATUS indicator	Indicates the power state (standby or normal operation) and the connection status to your Tx loudspeaker or WiSA-enabled device (TV/transmitter).
WIRELESS switch	Flip this switch to activate or deactivate the wireless function (WiSA).
PHASE switch	Flip this switch to set the acoustic phase to either 0° or 180°.
OUTPUT switch	Flip this switch to activate a high-pass filter at the analog output.
VOLUME	Control the subwoofer's volume.
FREQUENCY	Control the maximum frequency that should be reproduced from the subwoofer.
INPUT	RCA: Analog input stereo or RJ45 Stereo balanced analog input. Ideal for installations with long signal paths.
OUTPUT	RCA: Analog input stereo or RJ45 Stereo balanced analog input. Ideal for installations with long signal paths.
RESET	Hidden function to reset the subwoofer to the factory default.
SERVICE	USB input for firmware updates.

4 WIRELESS SURROUND SOUND WITH WISA

WiSA certified devices enable wireless, hi-res multichannel audio signal transmission for a fantastic home cinema soundscape.

Important: Make sure the «WIRELESS» switch is flipped to «ON» before attempting a wireless connection.

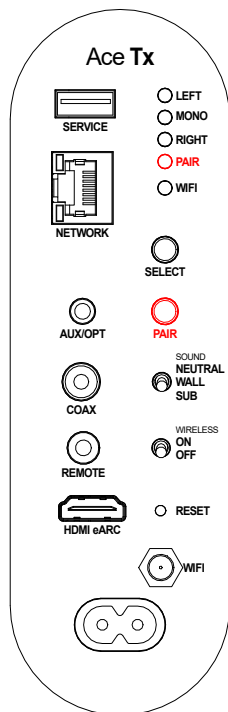

4.1 WIRELESS CONNECTION TO WISA-ENABLED DEVICE

For your WiSA device (TV, network player, etc.) to recognise your subwoofer press «PAIR» on your Sub Medium. The «PAIR» indicator starts to flash. Now follow the operating instructions of your WISA device.

4.2 CONNECT YOUR SUBWOOFER TO A PIEGA ACE WIRELESS SPEAKER

Connecting your PIEGA subwoofer to a PIEGA Ace loudspeaker (Tx) is really simple. Just press «PAIR» on both devices until the «PAIR» indicator starts to flash. Once the connection has been established, the indicator lights up permanently.

Important: Make sure the «WIRELESS» switch is flipped to «ON» before attempting a wireless connection.

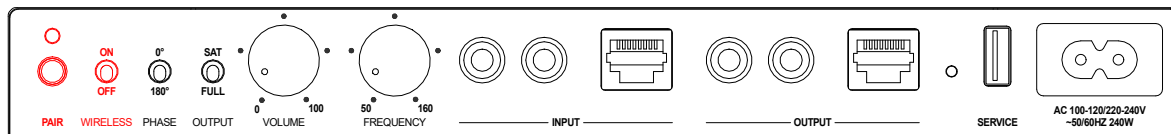

4.2.1 SUB MODE ACE WIRELESS SPEAKER

Our PIEGA sub medium is an ideal addition to the Ace Wireless loudspeaker series. Apart from allowing simple wireless integration, the speaker configuration will also be done automatically.

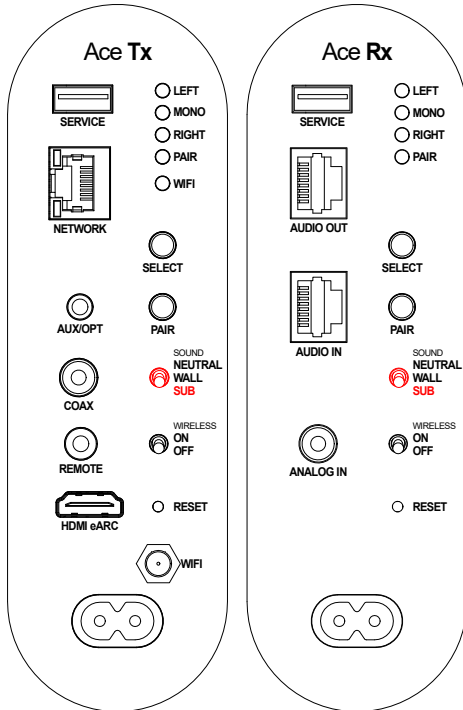

The frequency settings (adjusted by turning the «FREQUENCY» knob) from your Sub Medium will be used accordingly by your Ace speakers. To do so, you need to select the «SUB» mode on both your Ace speakers (Rx and Tx versions).

Important: Make sure to select «SUB» on every single loudspeaker.

In this «SUB» mode, the lower frequencies are reproduced by the subwoofer while the Ace speakers reproduce frequencies higher than the selected «FREQUENCY».

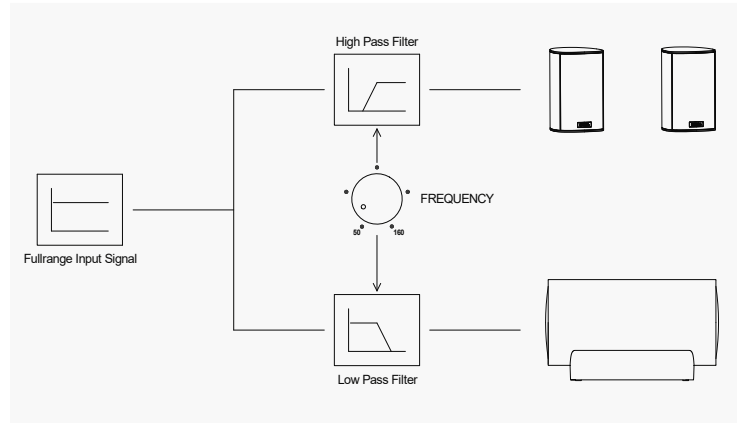

The upstream high-pass filter cuts the bass and relieves the stress of low bass being produced by your Ace speakers. This has a positive impact on the dynamic performance, the maximum volume, and the midrange reproduction.

Important: When using more than one Sub Medium, the highest frequency set is the one reproduced.

5 CONFIGURATION

5.1 POSITIONING

In principle, the subwoofer can be positioned to suit your personal preferences. However, placing the subwoofer near a wall or, more particularly, in the corner of a room can lead to increased bass reproduction at certain frequencies, which stimulates so-called room modes. If that's the case, allow for a little more space around your subwoofer. For best results, place your subwoofer between and slightly in front of your speakers or right next to them.

5.2 WIRELESS ON/OFF

With the «WIRELESS ON/OFF» switch, you can easily switch between wireless functions and analog input sources.

Function	Wireless OFF	Wireless ON
WiSA connection	OFF	ON
Analog input RCA & RJ45	ON	OFF

5.3 PHASE

This switch is used to determine the acoustic phase of your subwoofer.

If the subwoofer and main speaker are positioned at different distances from your listening area, extinctions or a peak in the bass range may occur, meaning you will either hear little, or too much bass. By setting the «PHASE», you can counteract this problem and bring your system into «PHASE».

Tip: Sit in your favourite listening spot and try both settings. Switch to the position in which the subwoofer appears to be louder.

5.4 OUTPUT

This switch exclusively affects the analog signal at the «OUTPUT».

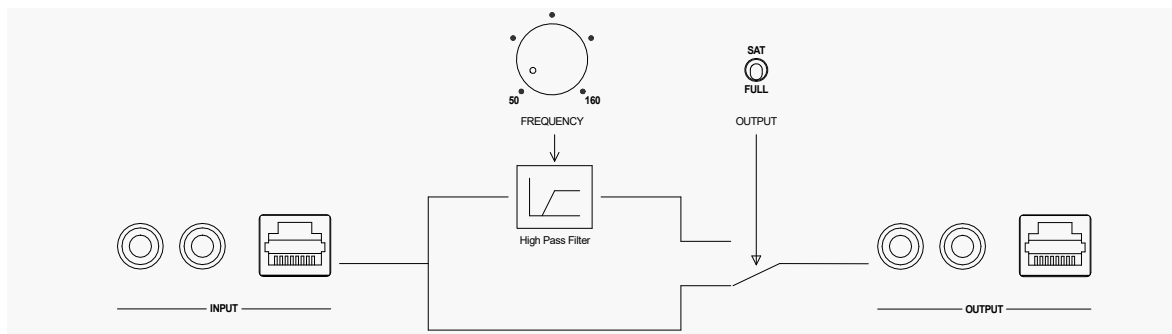
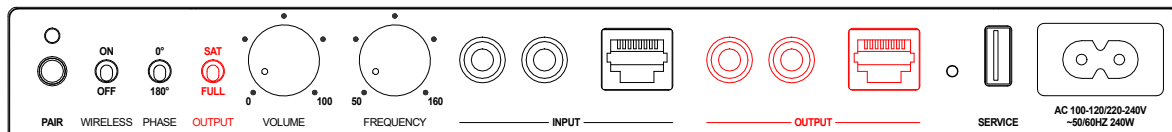

Position «FULL»: Audio signal is transmitted directly from «INPUT» to «OUTPUT».

Position «SAT»: Audio signal is transmitted through a high-pass filter from «INPUT» to «OUTPUT». Set the cut-off frequency of the high-pass filter by adjusting the «FREQUENCY» knob. The maximum subwoofer frequency thus matches the high-pass filter cut-off frequency.

5.5 VOLUME

This knob exclusively regulates the subwoofer's volume.

5.6 FREQUENCY

This knob sets the maximum frequency reproduced by the subwoofer. You can also use this to adjust the high-pass filter settings of your speaker. Learn more here: [OUTPUT](#) and [SUB MODE ACE WIRELESS SPEAKER](#)

6 ANALOG IN- AND OUTPUTS

6.1 RCA INPUT/OUTPUT

Via «RCA INPUTS» (Cinch), you can connect an analog stereo signal. The subwoofer then converts the stereo into a mono signal.

If you are using an AV receiver, we highly recommend using the «LFE» output of the AV receiver, which can then also be connected via stereo «RCA INPUTS». Both «RCA» terminals are equivalent and can be used for an «LFE» connection.

The «RCA OUTPUT» terminals are suitable for connecting a power amplifier linked to your main speakers.
Learn more here: [OUTPUT](#)

6.2 SCHNITTSTELLE FÜR DIE PROFI-INSTALLATION

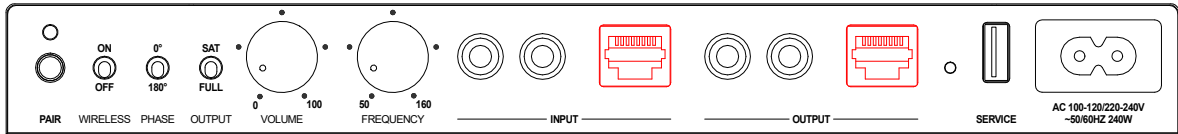

Your PIEGA subwoofer is equipped with a balanced analog input. The built-in RJ45 jacks allow for inexpensive and easy installation, and the signal can be routed via standard CAT network cables. It's imperative to use shielded cables and RJ45 plugs.

The following graph provides an overview of the pin assignment of the RJ45 connector.

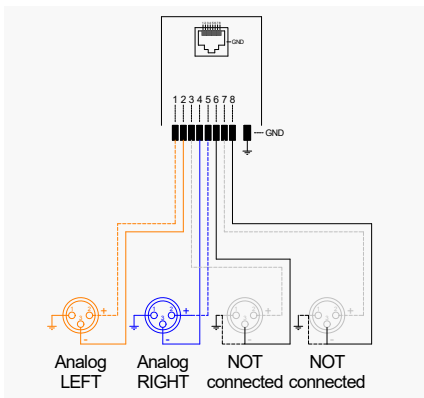

RJ45 Pin	Input	Polarity
1	Balanced Analog Left	+
2	Balanced Analog Left	-
3	NOT connected	
4	Balanced Analog Right	-
5	Balanced Analog Right	+
6	Ground	GND
7	NOT connected	
8	Ground	GND
GND	All	GND

The signal is internally routed from RJ45 «AUDIO IN» to RJ45 «AUDIO OUT».

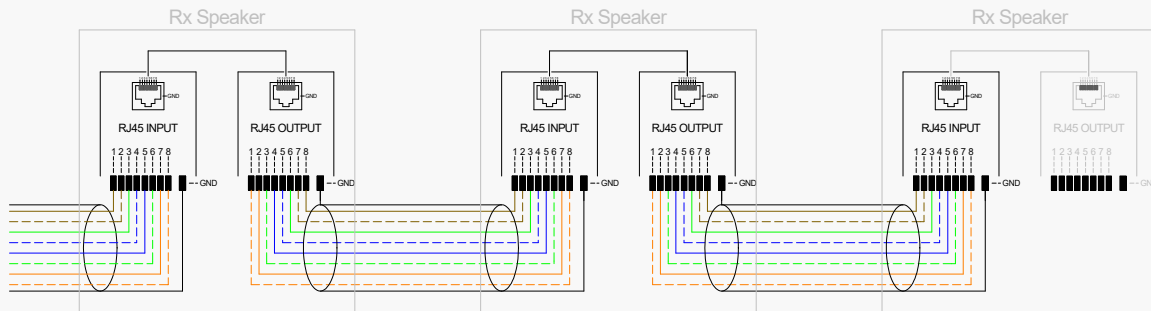

Note: Make sure the «WIRELESS» switch is set to «OFF».

7 RESET

To perform a reset to factory default, use a pointed object to push the «RESET» button. The following settings will be deleted: WiSA connection (connection to WiSA TV or Tx speaker)

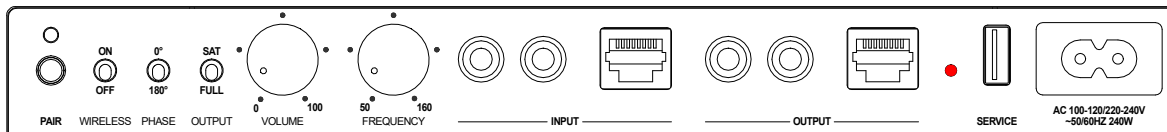

8 FIRMWARE UPDATE

Um ein Firmware-Update auf deinen Lautsprechern durchzuführen, sind folgende Schritte notwendig:

1. Disconnect your speakers from the power supply.
2. Save the new firmware on a USB flash drive.
3. Connect the USB flash drive to the «SERVICE» port.
4. Connect your speakers to power.
5. The «PAIR» indicator lights up, flashing red throughout the entire update.

Note: Make sure to save the new firmware to the top level of your USB stick and refrain from using subfolders.

9 STATUS INDICATOR

The following table lists the different status indicators when the «WIRELESS» switch is «ON»:

Status Indicator	Colour Indicator	Details
Short flashing	White	Wireless connection failed
Blinking	White	Establishing wireless connection
Steady on	White	Connection established, normal operating mode
Steady on	Red	Standby mode

The following table lists the different status indicators when the «WIRELESS» switch is «OFF»:

Status Indicator	Colour Indicator	Details
Steady on	White	Normal operating mode
Steady on	Red	Standby mode

10 TECHNICAL DATA

Wired inputs		WiSA (Wireless)	
Analog RCA	48kHz / 24Bit	Data rate	48 – 96kHz / 24Bit
Analog stereo balanced	48kHz / 24Bit		
Power		Frequency	
Output power @<1% THD	240W	Frequency response	18 – 160Hz
Maximum input power	240W	Low pass filter range	50 – 160Hz
Mechanic			
Assembly	2 × 200 mm		
Dimensions	230 × 270 × 465 mm		
Weight	17.5 kg		
Supply			
Voltage	100 – 240V 50/60Hz		

11 DECLARATION OF CONFORMITY

PIEGA AMP/speaker is in conformity with the following directives:

LVD:2014/35/EU
EMC:2014/30/EU
RED:2014/53/EU
ERP:2009/125/EU
ROHS:2011/65/EU
REACH:1907/2006/CE

STANDBY

After 60 minutes without any incoming music, the device will automatically go into a normal standby mode. This is indicated by a red light on operating status display, and the power consumption goes down below 0.5W. The device will automatically wake up upon receiving a music signal, but we encourage you to completely turn off your device when not in use for an extended period of time.